

GP042-0015,1

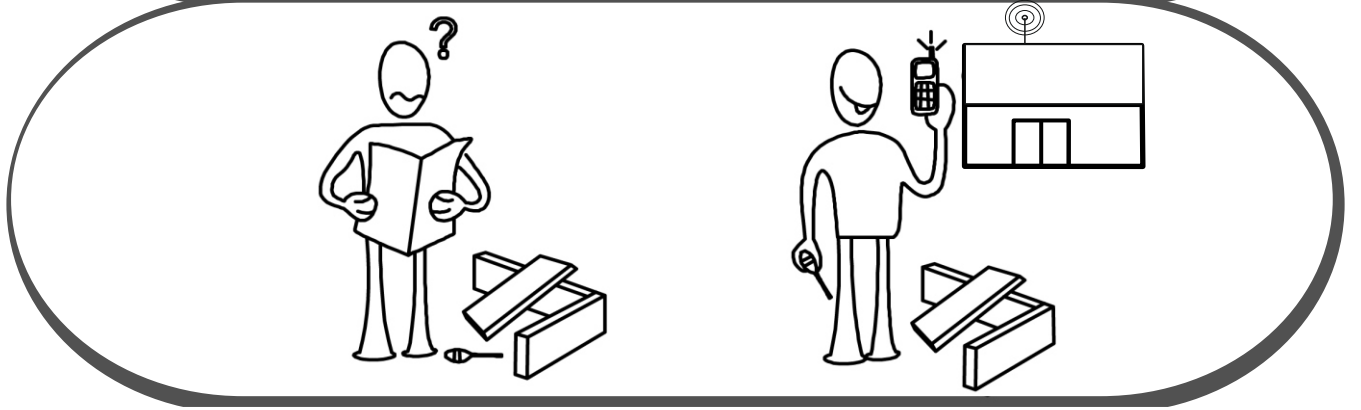

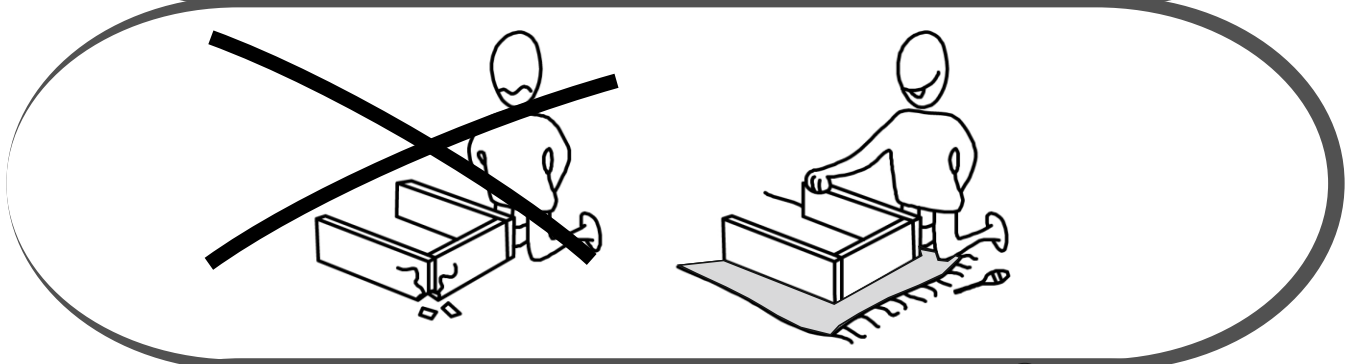

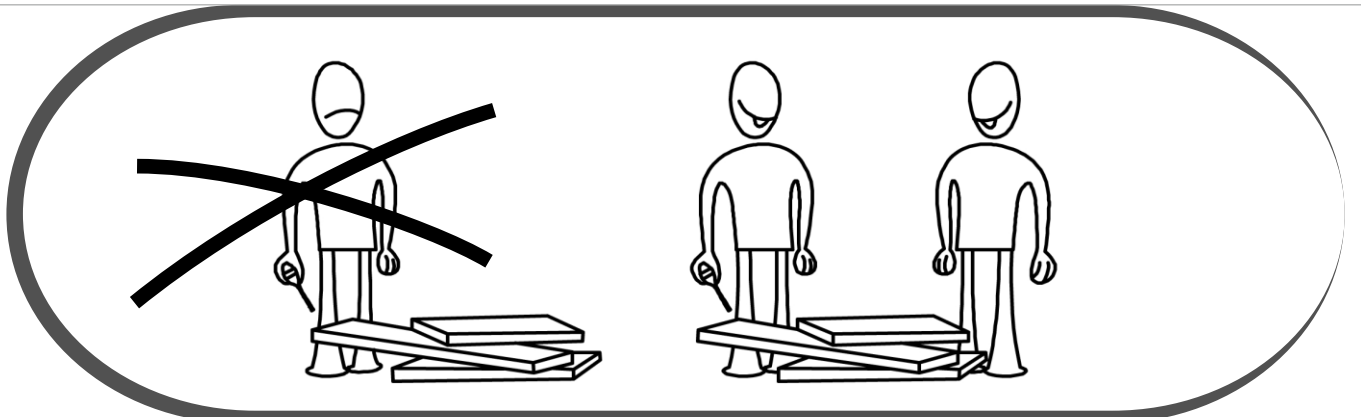

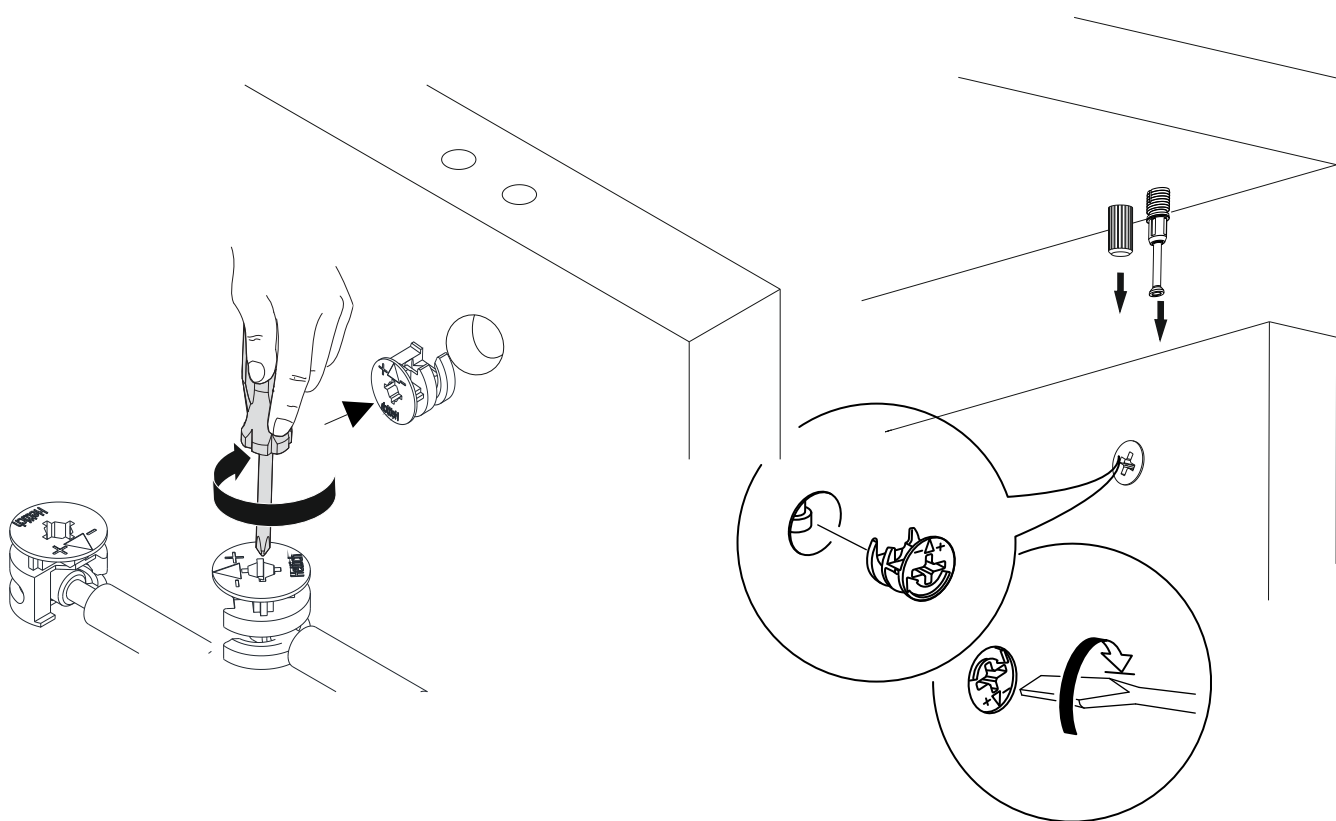
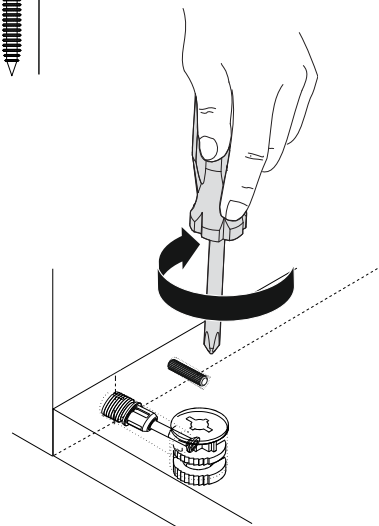
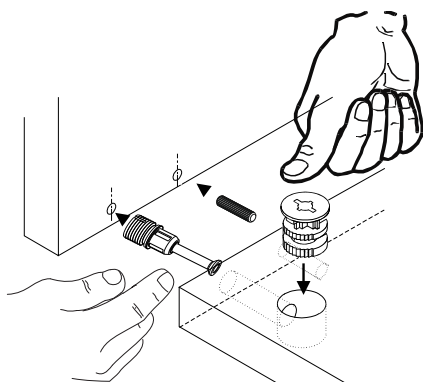
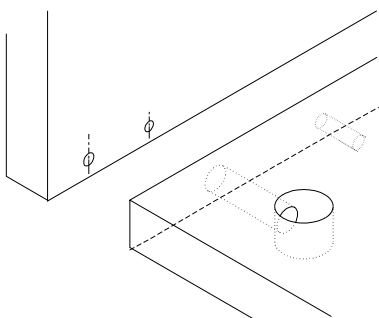
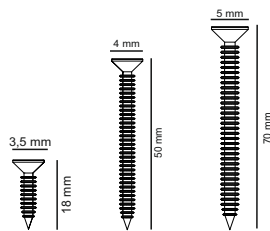
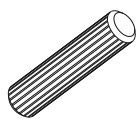
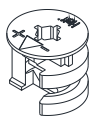
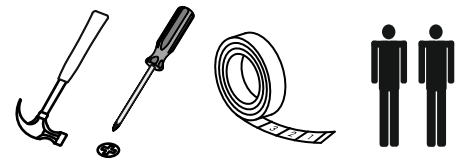

The necessary tools (not included)

ACCESSORY LIST

A01 40x	A02 32x	A03 32x	A04 A 40x	A06 UM(Sgml) 4x
A10 3,5x18 YHB 19x	A13 MA 4x	A11 SPM 4x	A07 -L- 3x	A08 Ø8 3x
A09 4x50 YHB 3x	A29 3,5x30 YHB 20x	D17 5x	A28 24x	

GENERAL VIEW

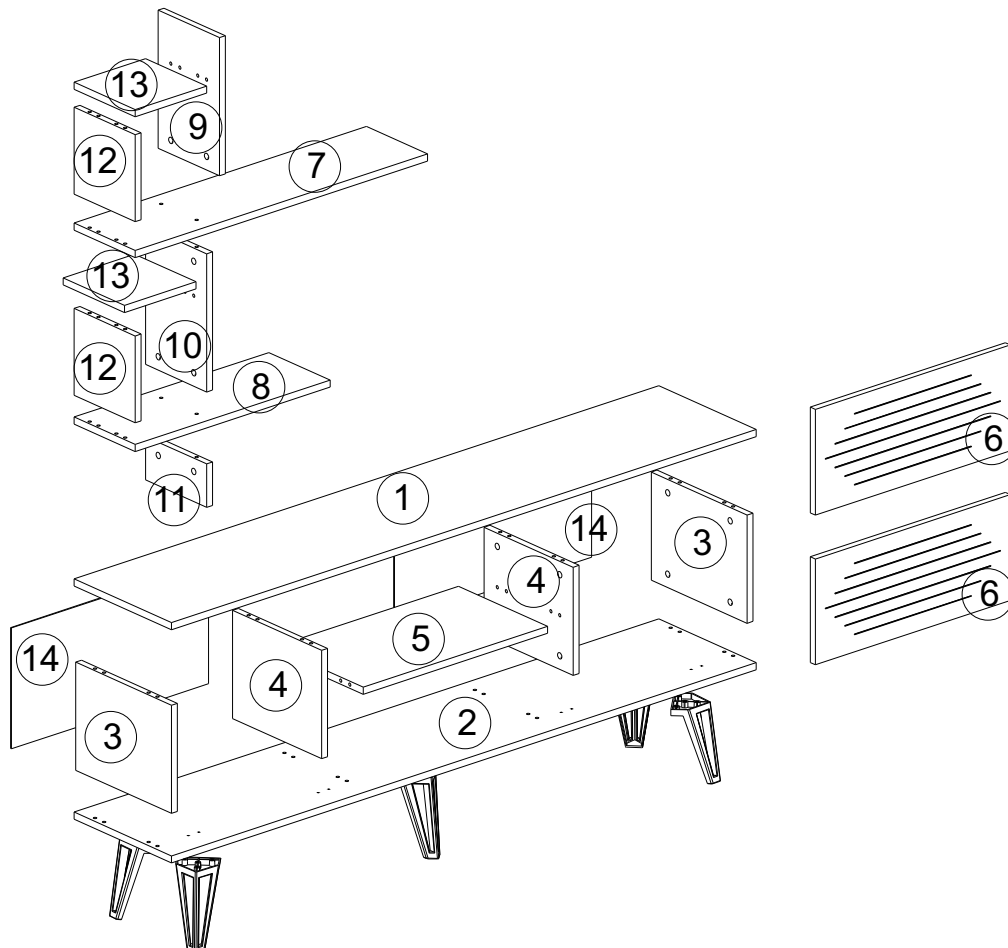

1

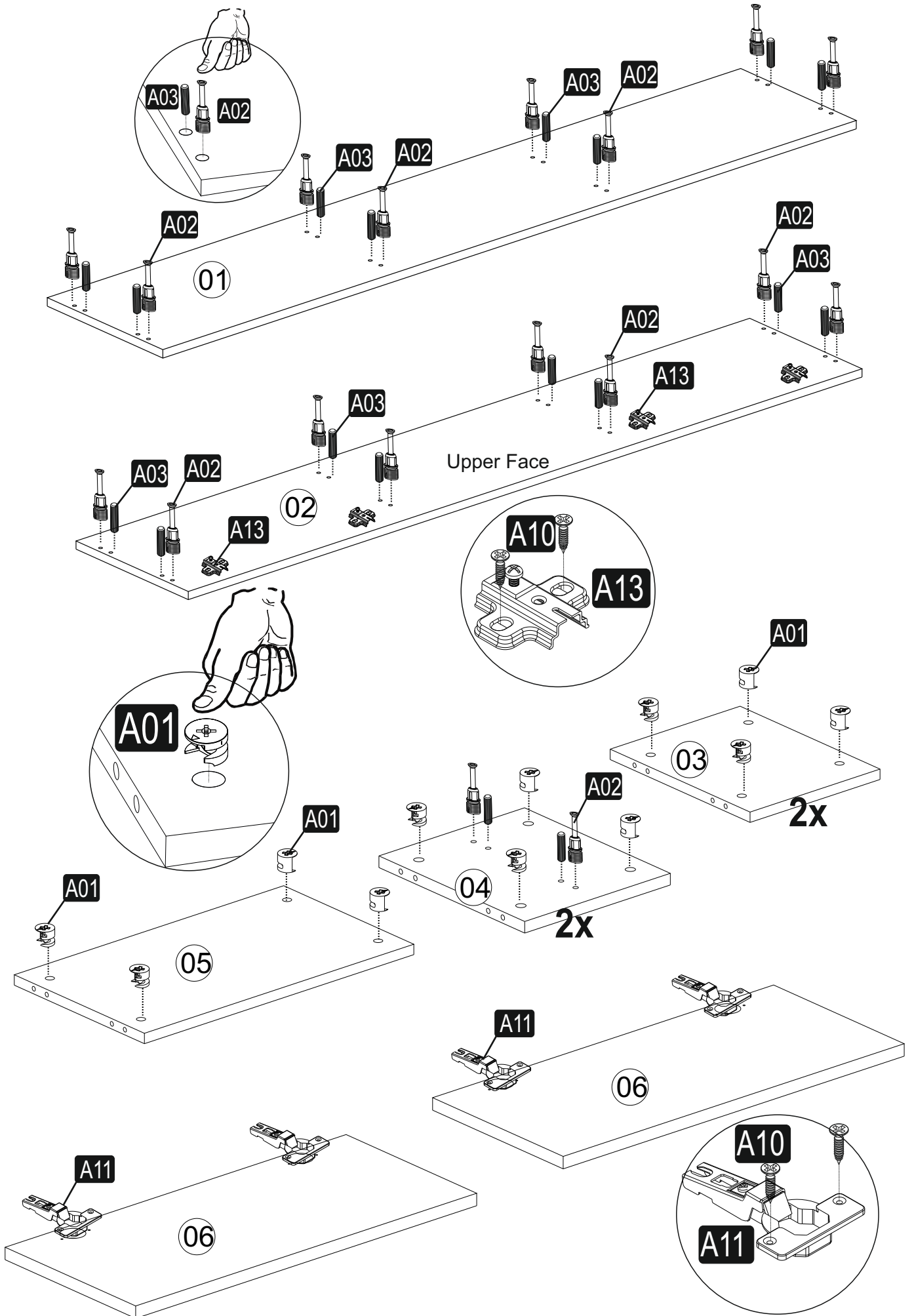

2

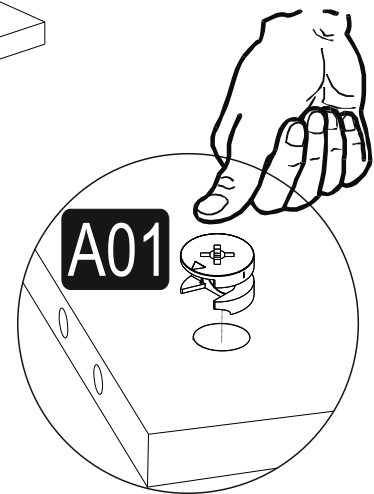
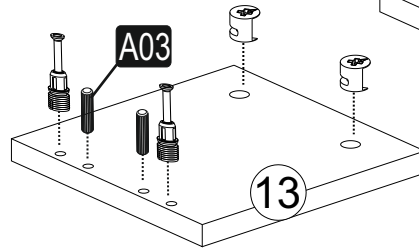
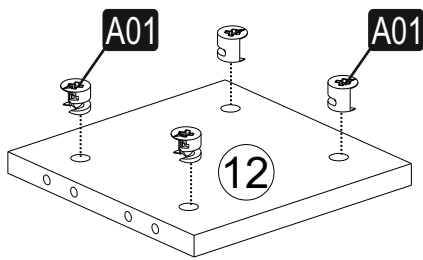
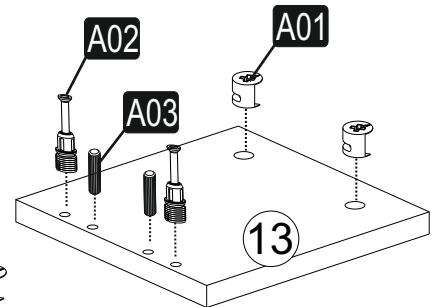
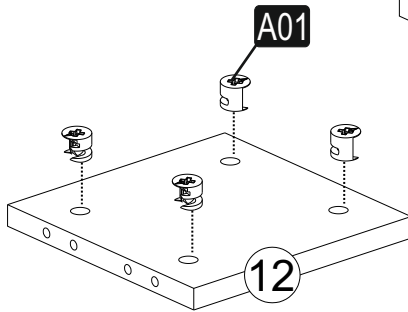
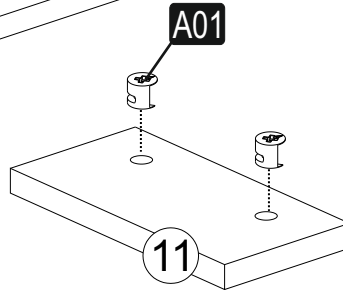
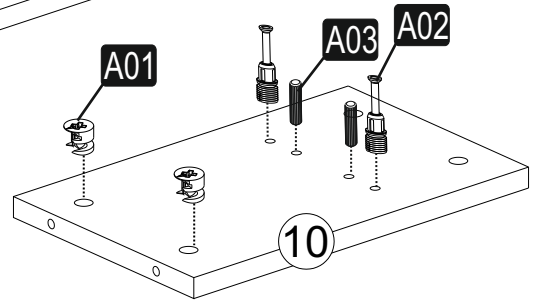
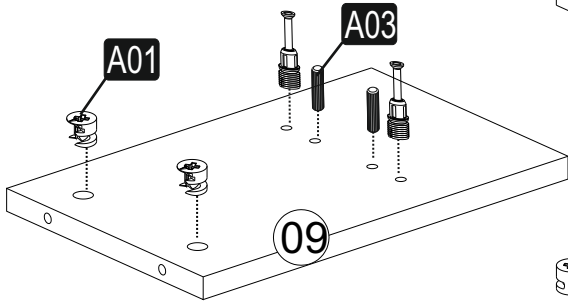
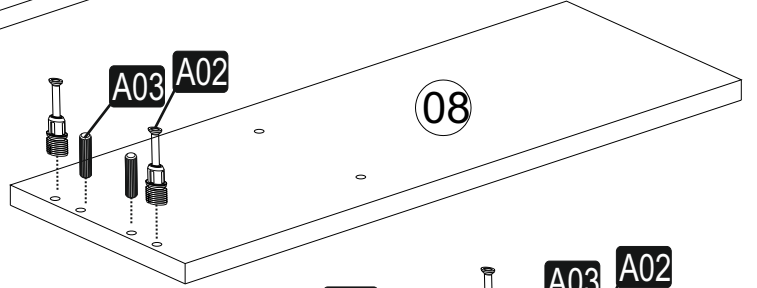
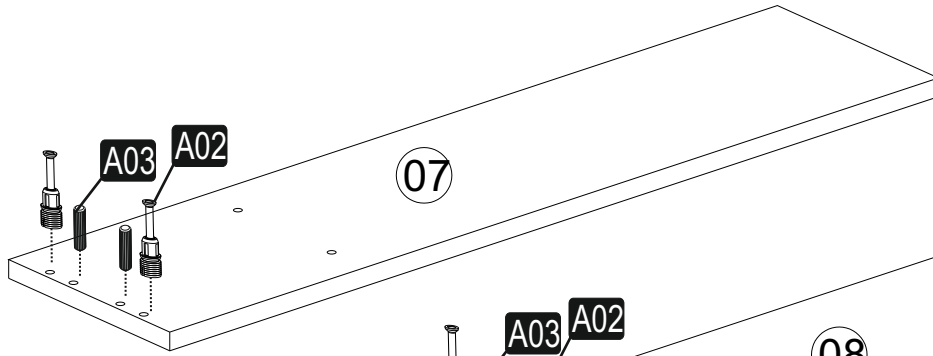
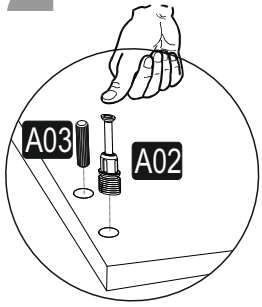

3

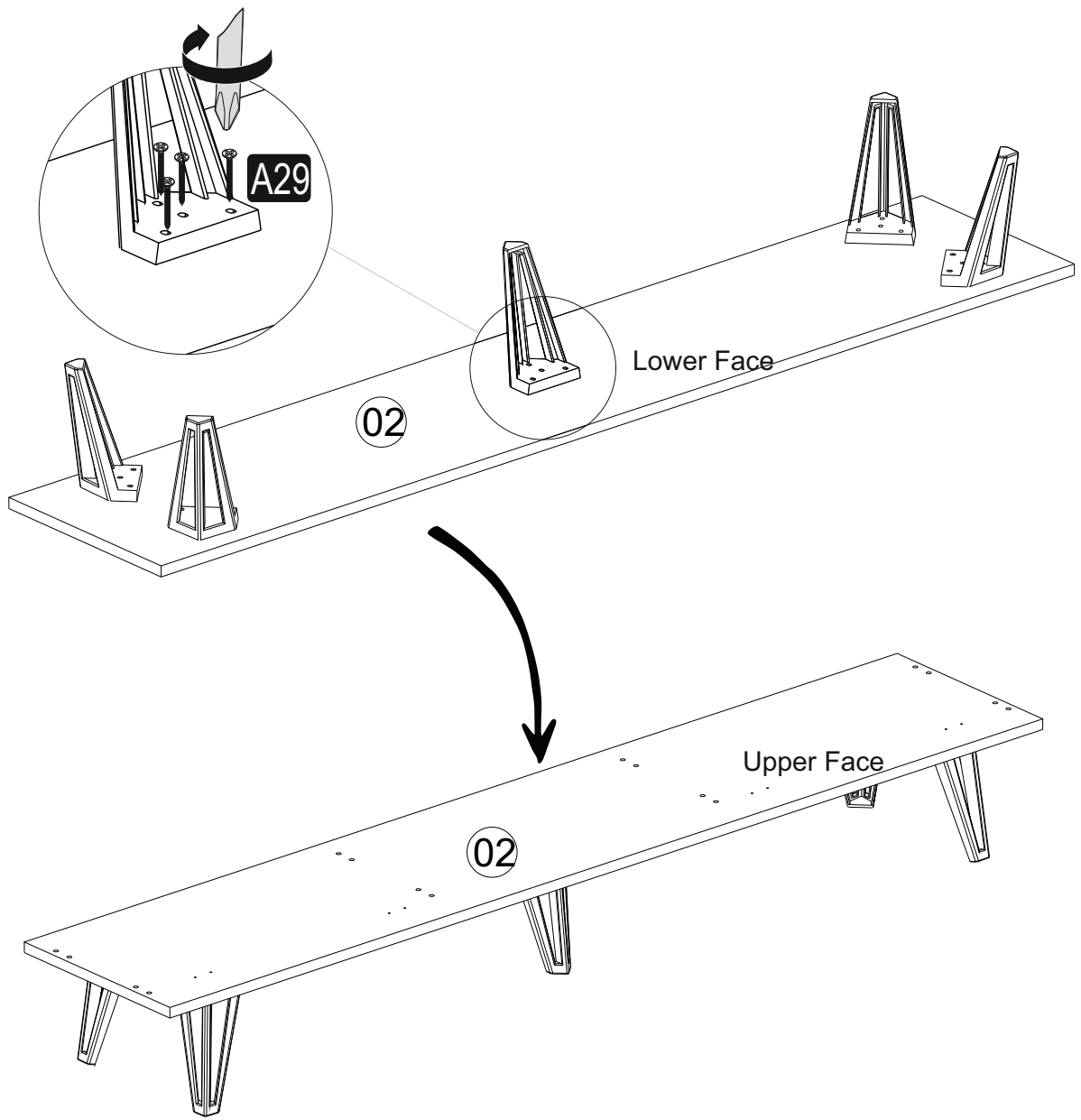

4

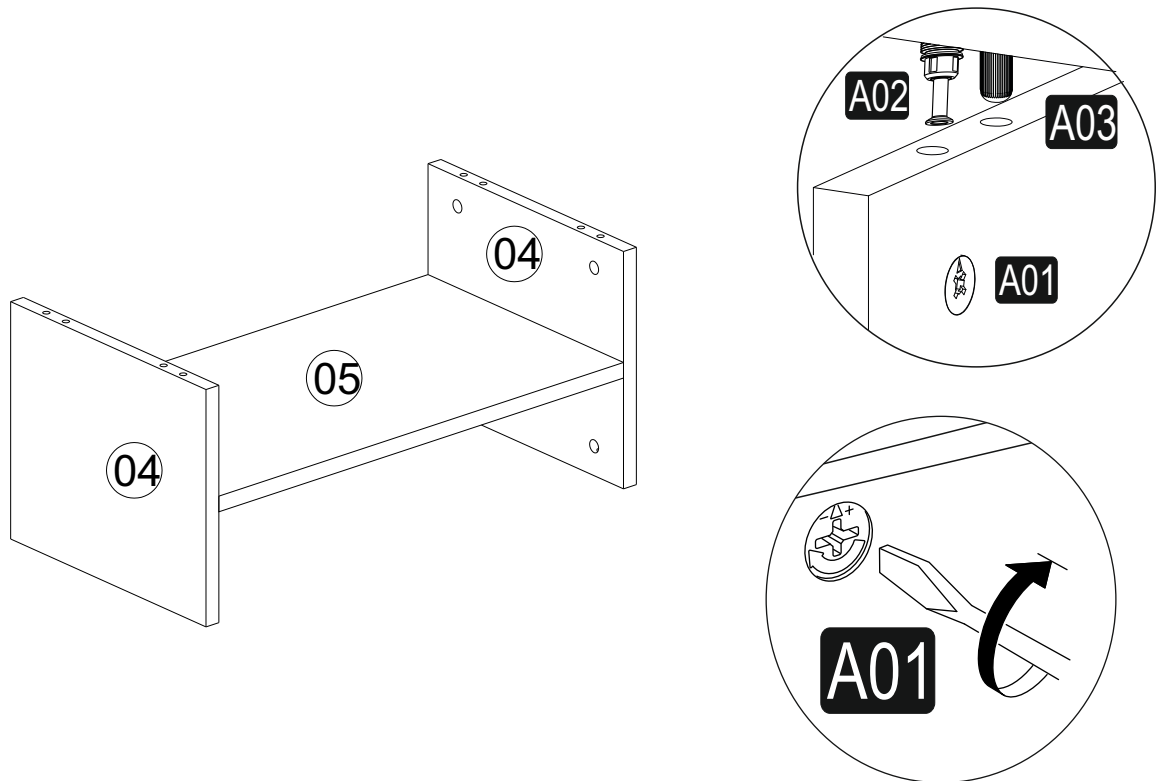

5

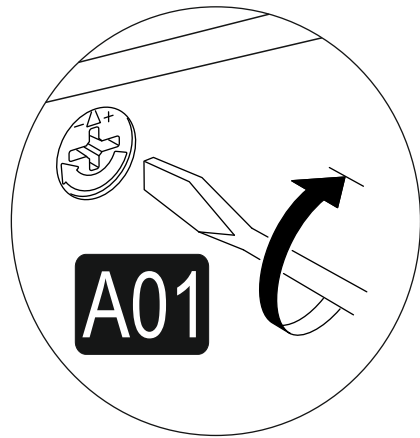
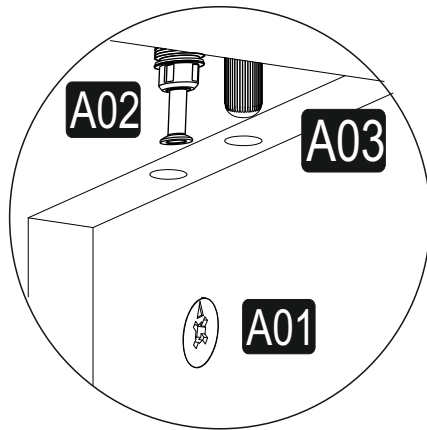
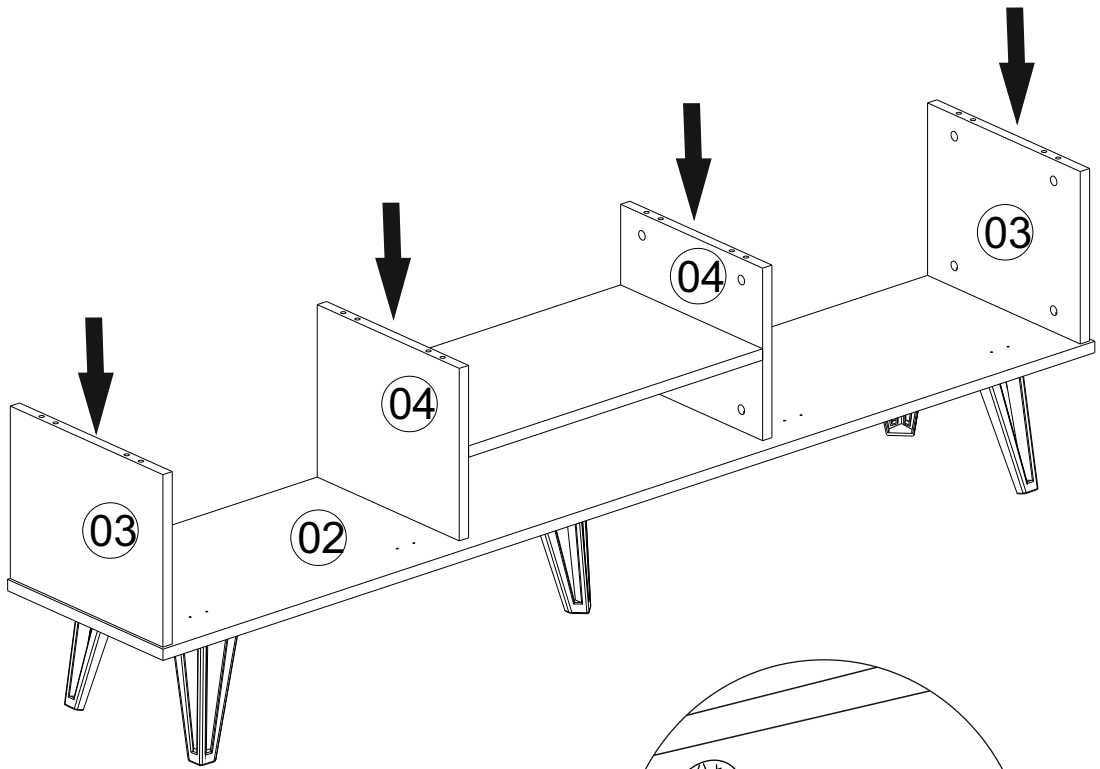

6

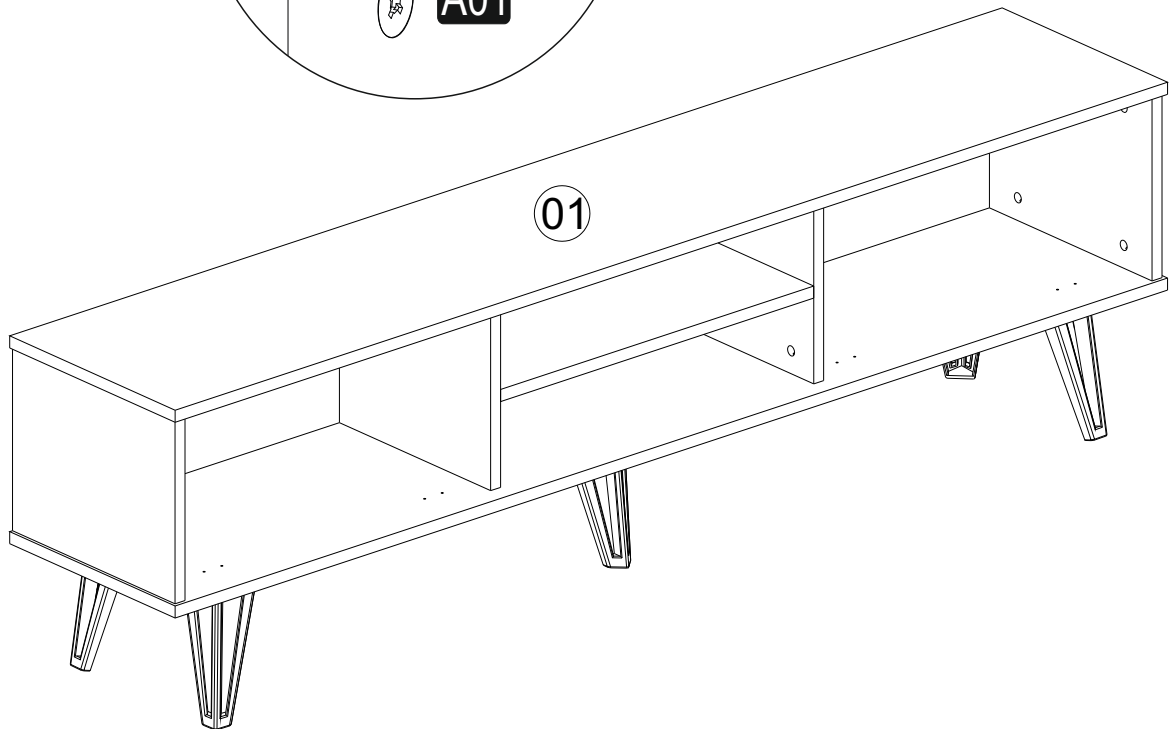

7

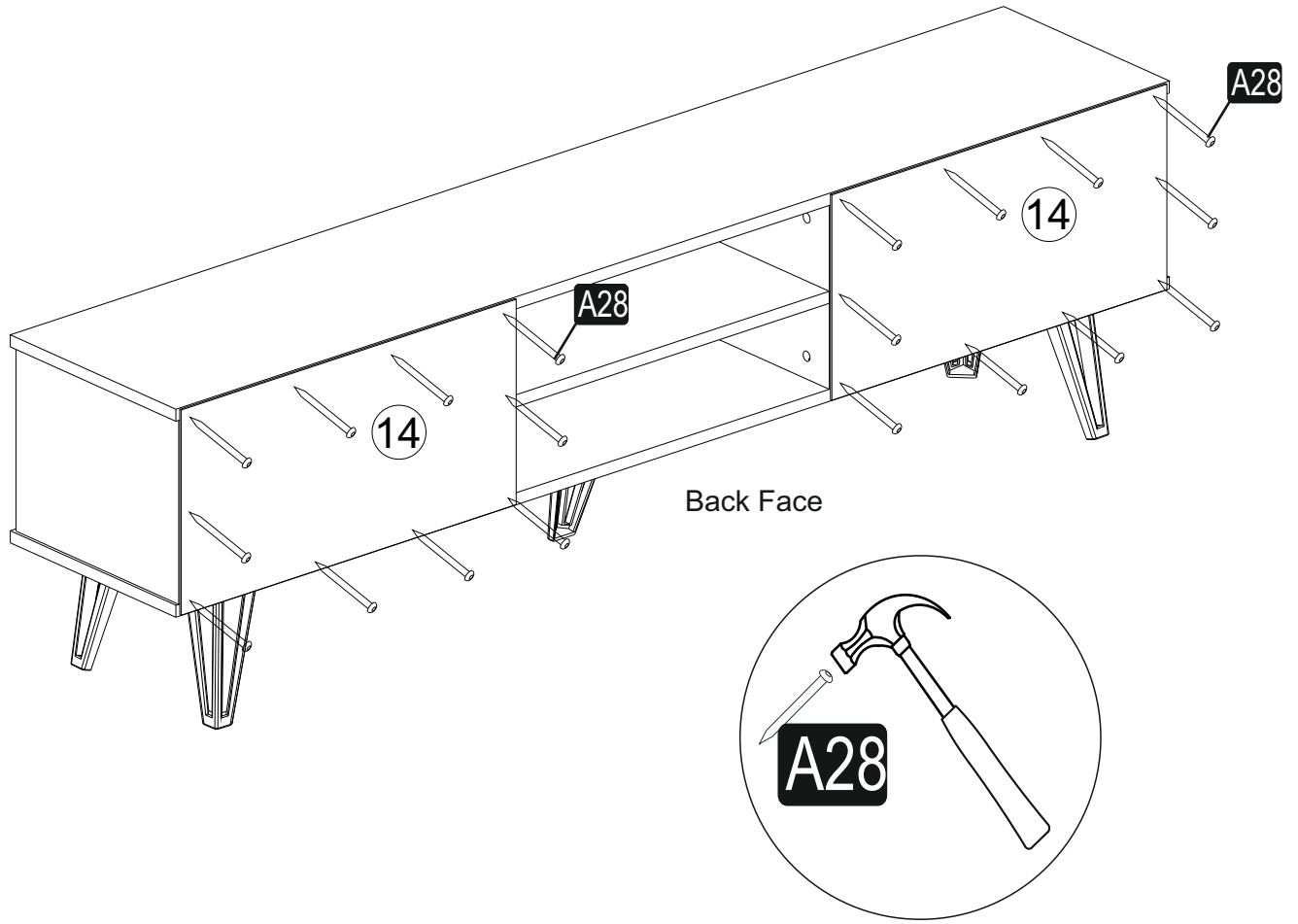

8

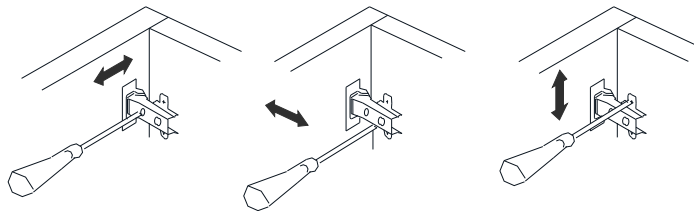
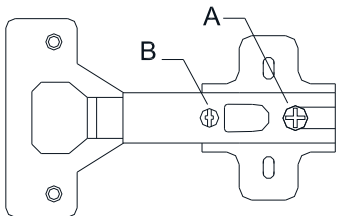
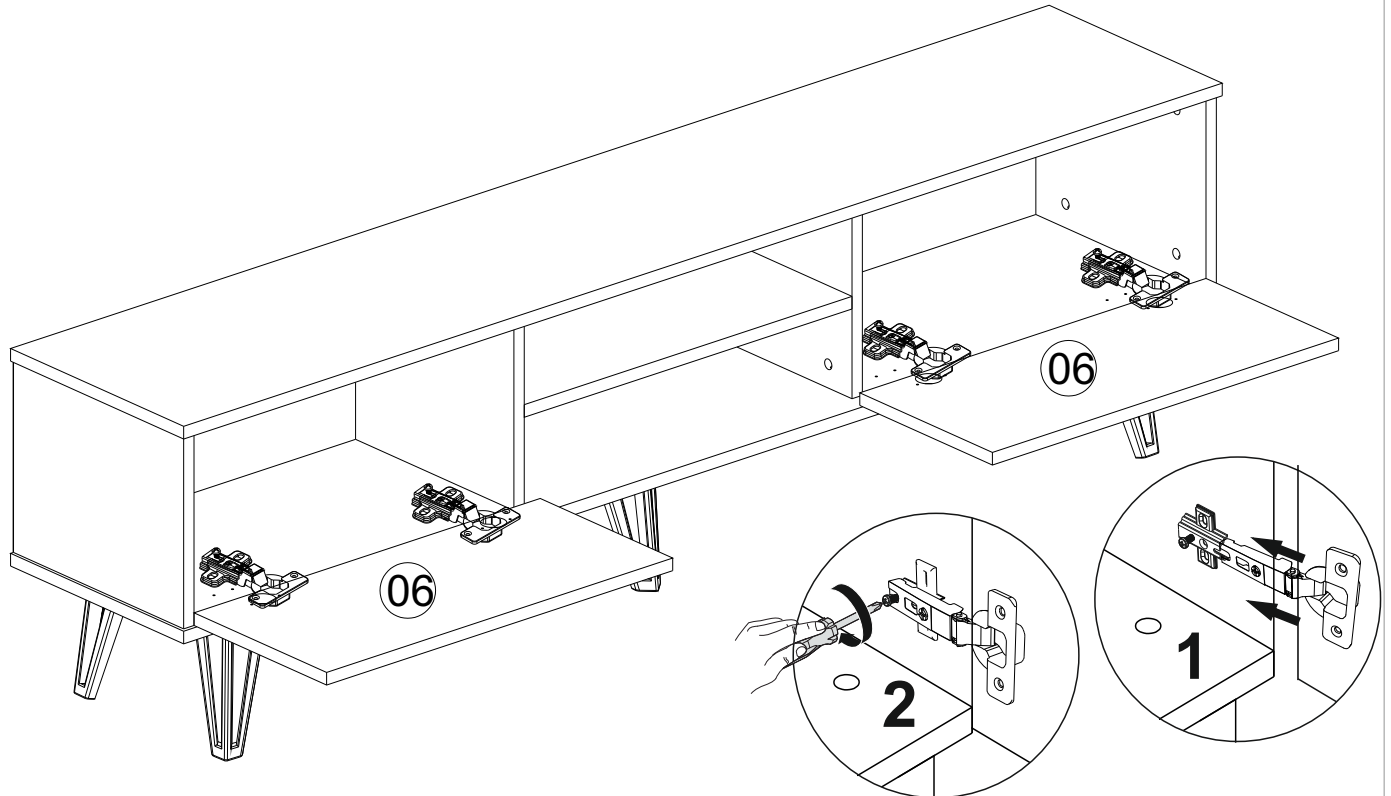

A= to connect the hinge to the door
 B= to arrange the door

arrows to show the directions for arrangement of doors.

9

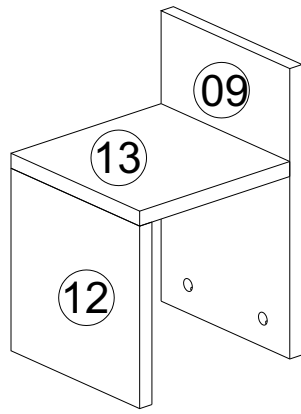

10

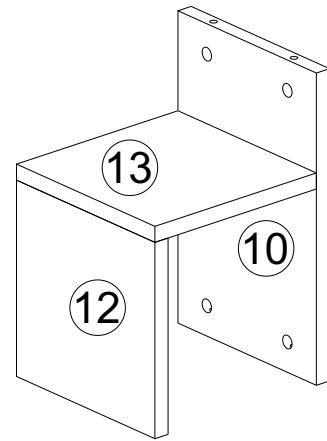
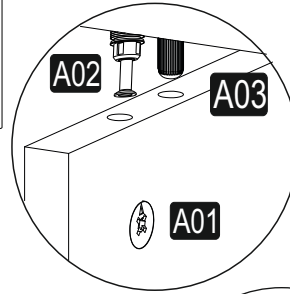

11

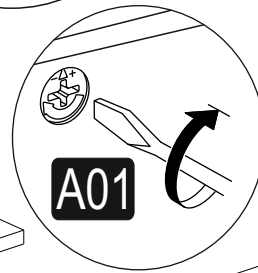
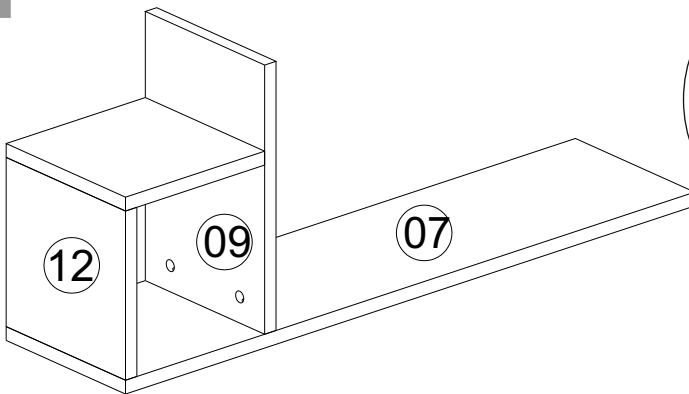

12

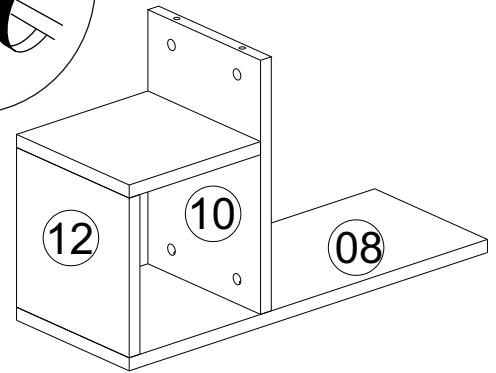

13

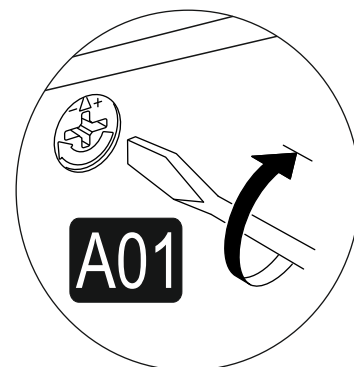
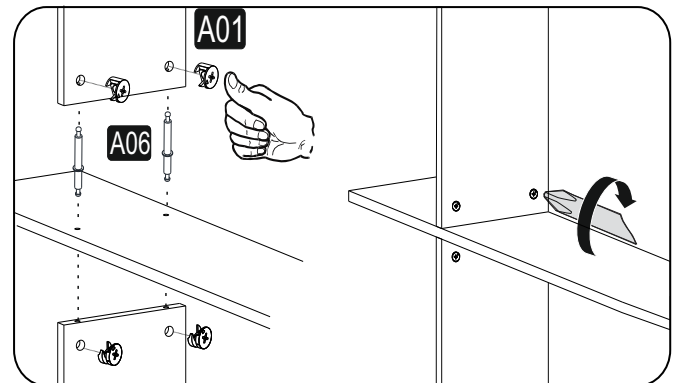
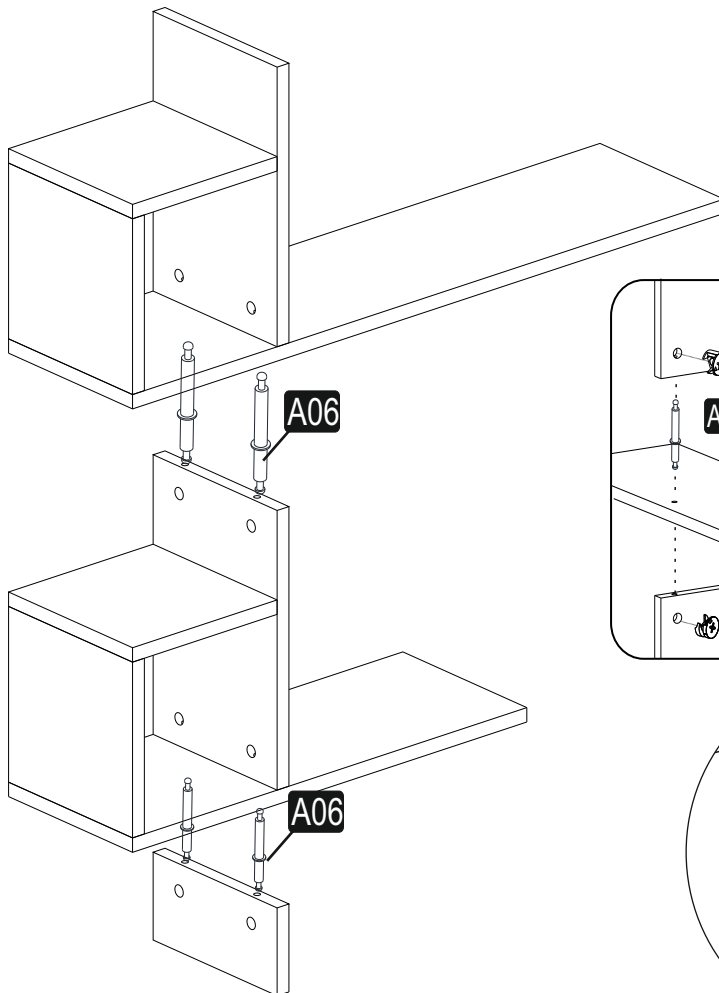

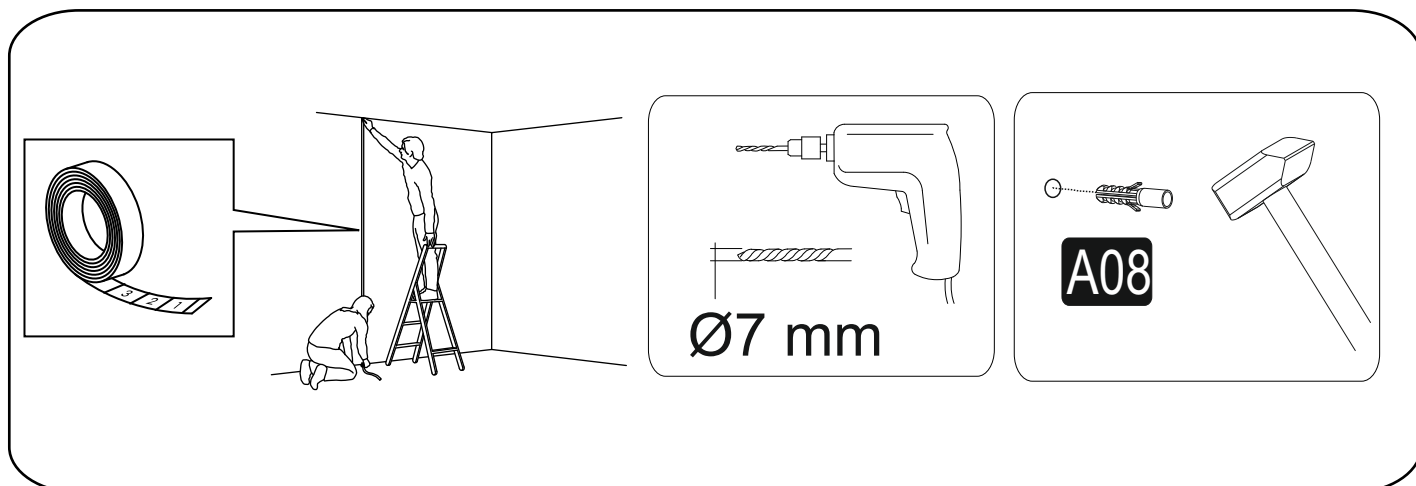
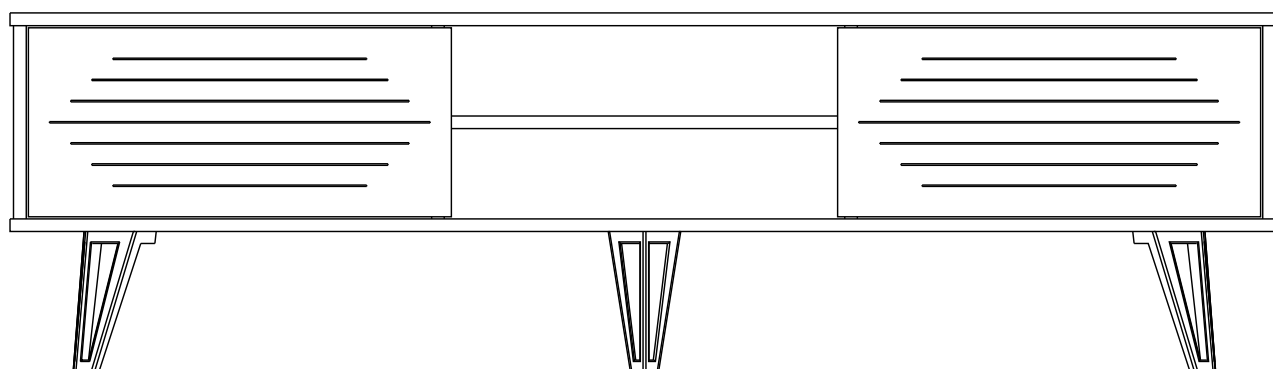
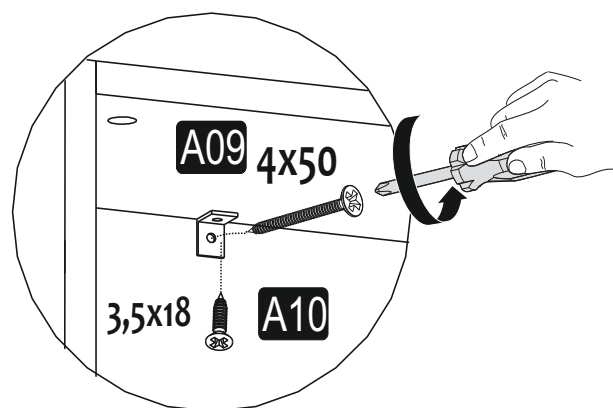
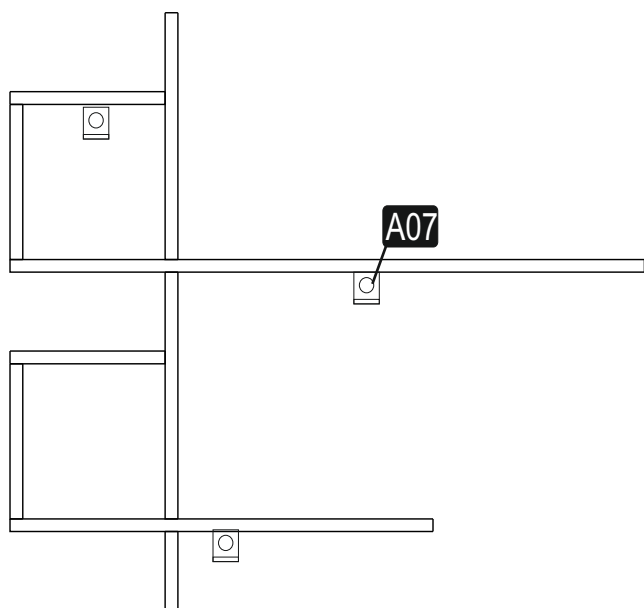

15

